

# HOBBYNOX™

## TARA

***Top Feed Airbrush Set with 0.2/0.3/0.5 mm Nozzles***



# MANUAL

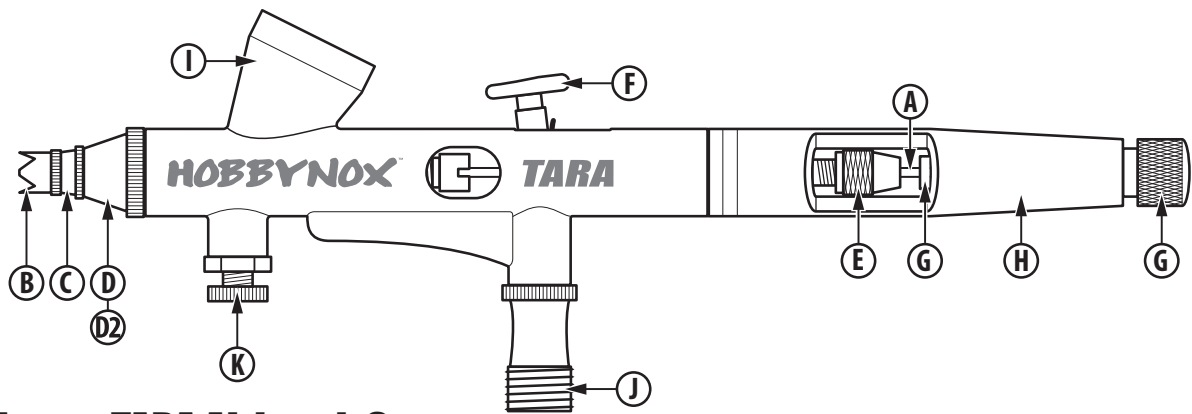

## Hobbynox TARA Airbrush Set

First we want to thank you for purchasing the Hobbynox TARA top-feed double-action airbrush set. The TARA is the perfect first “detail” airbrush that is meant to be used with waterbased non-toxic paints such as our Hobbynox Airbrush Colors or similar from Createx, Faskolor or any other thinner viscosity airbrush paint. It’s suitable for most types of small and detailed airbrush work such as small to medium sized models and custom detailed airbrush work. The TARA has a nozzle/tip construction that is optimized for detail work with better atomization of the thinner viscosity paints that is mostly used when painting small items. The TARA is a complete set that is ready to be used and it connects easily to the Hobbynox Airbrush Compressors or any other airbrush compressor that has an G1/8 male threaded coupler.

### Included Items:

- Hobbynox TARA - Top Feed Airbrush Set - #HN003-00
- Needle/Tip Sets - 0.2 (std mounted), 0.3 & 0.5 mm
- Paint Cup - 2 cc
- Braided Hose - 1.8 m long - G1/8 Female & G1/8 Female
- Compressor Adapter - G1/8 Male to G1/4 Female
- Printed Manual & Tip Tool

## Description

- A. Needle.** Out of the box there is a 0.2 mm needle set installed in your TARA airbrush. To remove the needle, first unscrew the back handle (H) and then by hand untighten the threaded needle holder clamp nut (E). Then carefully pull back the needle out of the needle holder unit. Be careful to not bend the sharp tip of the needle!
- B. Funnel Cap.** The funnel cap directs the paint that comes out of the nozzle/tip and is threaded in place with hand tight pressure. The TARA airbrush can be used without the cap if you are painting fine details but be careful not to bend the tip of the needle as it will be exposed!
- C. Nozzle.** The nozzle is hand threaded medium tight.
- D. Air Cap.** The air cap holds and the small needle tip and it’s hand tightened with the included tool.
- D2. Needle Tip.** The small tip is matched to the needle and it’s a 0.2 mm tip installed from the factory (a 0.3 & 0.5 mm set is also included in the box).
- E. Needle Clamp Nut.** It’s hand tightend to hold the needle to the needle holder unit. Unscrew it 1/4-turn when removing the needle.
- F. Trigger.** Push down for gradually more air and pull back to gradually increase paint flow.
- G. Back-Stop Adjustment.** The rear nut is threaded to allow adjustments of the back-stop movement of the needle unit. That can be useful if one wants to limit the maximum possible paint flow (when trigger is fully back).
- H. Rear Handle.** Use only light force when tighten it.
- I. Paint Cup.** The integrated paint cup is 2 cc small and cleans easily.
- J. G1/8 Male Thread.** Tighten the included hose adapter with medium force.
- K. Micro Pressure Control.** As the TARA airbrush is made to paint small items the air pressure can be critical and many times needs to be adjusted precisely.

- Included - #HN003-02A - 0.2 mm Needle & Tip Set
- Included - #HN003-02B - 0.3 mm Needle & Tip Set
- Included - - 0.5 mm Needle & Tip Set

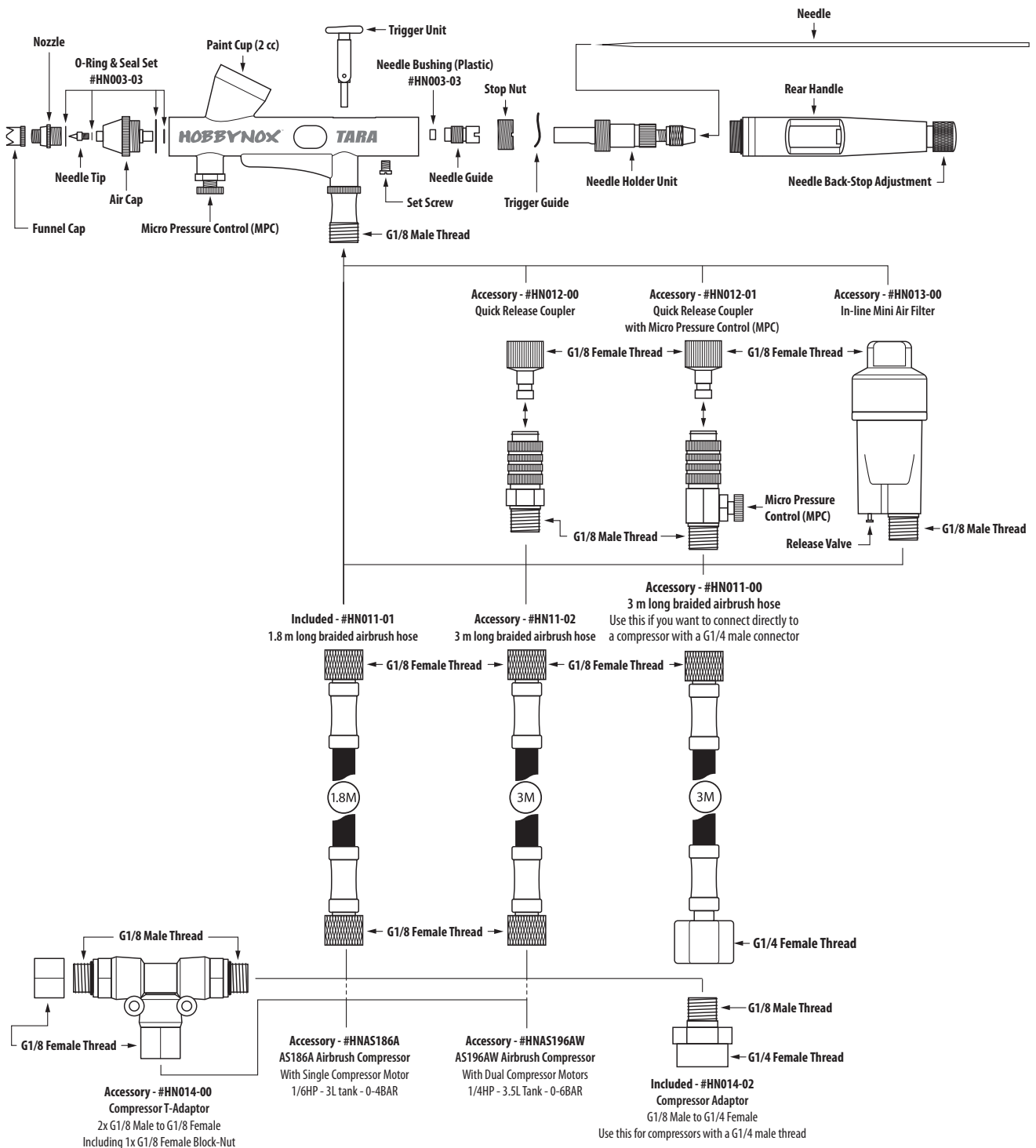

- HN003-01A ...TARA - 0.2 mm Needle & Tip Set.....
- HN003-01B ...TARA - 0.3 mm Needle & Tip Set.....
- HN003-02 ....TARA - O-Ring Set.....
- HN011-00 ....3.0 m Braided Hose - G1/8 Female x G1/4 Female.....
- HN011-01 ....1.8 m Braided Hose - G1/8 Female x G1/8 Female.....
- HN011-02 ....3.0 m Braided Hose - G1/8 Female x G1/8 Female.....
- HN012-00 ....Quick Release Coupling - G1/8 Female & G1/8 Male.....
- HN012-01 ....Quick Release MPC Coupling - G1/8 Female & G1/8 Male.....

- HN013-00 ...Mini Air Filter - G1/8 Female & G1/8 Male.....
- HN014-00 ...Compressor T-Adaptor - 2x G1/8 Male & G1/8 Female.....
- HN014-01 ...Compressor Adapter - G1/8 Female & G1/4 Male.....
- HN014-02 ...Compressor Adapter - G1/8 Male & G1/4 Female.....
- HN018-00 ...Airbrush Cleaning Station (incl. 3 filters).....
- HN018-01 ...Spare Filters to Airbrush Cleaning Station (10pcs).....
- HN017-00 ...Airbrush Holder 2+2 (with Air Regulator Holder).....
- HN013-01 ...Air Regulator & Manometer Unit.....

## Learning to Airbrush

If you are starting your new airbrushing hobby you will quickly notice that it's very fun and creative - the sky is the limit on what you can do with it!

When you are new to airbrushing it's a lot to learn and we recommended that you test different techniques to learn what works best for you.

For more info search for example youtube and you will get plenty of videos that show different airbrushing techniques etc.

*Note, there is not two individuals that airbrush the same!*

## Thinning the Paint

Use the manufacturer recommended paint reducer. With modern waterbased paints though you may get away with using just water as a reducer. But with water as a reducer you can get yourself into issues though as eventually the water content in the mixed paint gets too high and that can create not preferred end results including excessive tip/nozzle paint clogging.

At least do yourself a favor and buy a bottle of the manufacturer recommended reducer and test it to see the difference.

### Not Enough Reducer:

- Excessive clogging of the airbrush tip/nozzle.
- Cobwebbing of the paint - as in the paint dries before it even hits the surface to be painted.
- You can hear a "dry noise" from the airbrush nozzle while painting.
- Solution: Add more reducer and/or increase air pressure.

### Too Much Reducer:

- Paint runs (that can also happen if you are airbrushing too close to the painted surface or too high air pressure).
- Paint coverage is weak.
- Solution: Increase the distance from the airbrush nozzle vs the surface to be painted, add more paint to the mix (making the paint mix thicker) and/or lower the air pressure.

## Air Pressure

Normally the air pressure needs to be stable and constant. For that reason we recommend an airbrush compressor with a 3L air tank and that it can produce around 20 liters of airflow per minute to be on the safe side with the TARA. The air pressure range that is normally used is around 1.5-2.5 BAR depending on the needle/tip size and how small details you will paint.

## Recommendations

### Small Details & Thinner Paint = Lower Air Pressure

**& Smaller Tip Size:** With the TARA airbrush that means you will mostly use the standard mounted 0.3 mm needle/tip set. With this set-up you can paint most smaller items such as plastic models, fishing baits and detailed custom details. For really detailed work use the even smaller 0.2 mm needle/tip set and reduce the paint & air pressure even more. With both needle/tips you can remove the front funnel cap which makes it possible to come even closer to the surface you are painting.

### More Covering & Less Thin Paint = Higher Air Pressure

**& Bigger Tip Size:** The TARA is not an airbrush you should choose if you plan to paint medium or larger items. But you can buy the 0.5 mm needle/tip set separately if you want to test.

## Airbrush Issues

Normally any issues you will have regarding the function of your airbrush is due to not enough maintenance or that you have an air leak somewhere.

So of that reason the cleaning, disassembly and reassembly of your airbrush is the most important things to do correctly and frequently to get a good constant function.

If there is no paint coming through the tip/nozzle it's most likely clogged with paint build up. Clean it again and maybe increase the amount of reducer in the paint mix to reduce the clogging and increase the air pressure. Try also to go one step up on the needle/tip size or just adjust the needle backwards to allow more paint to flow through.

If it's air bubbles in the paint cup there is most likely an air leak. Re-tighten the funnel cap, nozzle and/or air cap.

## Cleaning Your Airbrush

If you use our Hobbynox Airbrush Colors then you can use normal tap-water to clean most parts of your Hobbynox TARA airbrush. Don't let the paint sit in the airbrush for too long though or it can get difficult to flush out - it's best to clean the airbrush directly after you are done painting.

If water is not enough to remove the paint residue - Use our Hobbynox SP Reducer/Cleaner!

If possible don't use any other type of paint thinner to clean the airbrush with as the o-rings can get damaged.

### Cleaning Procedure:

1. Empty the paint cup from any remaining paint into the waste bin. Remove excessive paint inside the cup with a paper towel.
2. Fill the paint cup with water and pull back/push down the trigger and put the airbrush into a cleaning station or aim it down into a waste bin. Flush the airbrush until there is no visible paint left and the water that is sprayed out is clean.
3. Fill the paint cup with our Hobbynox SP Reducer/Cleaner and flush the airbrush with it. Use a small nylon paint brush to help remove any paint that is still left.
4. Use a paper towel and hold it in front of the nose of the airbrush and pull the trigger all the way back and push the trigger down. You will create a back-pressure and paint that is still inside the airbrush will come out inside the cup. Clean the cup with a paper towel. Repeat if necessary.
5. Use a paper towel and SP Reducer/Cleaner to clean the outside of the airbrush. Done.
6. Every once in a while take the airbrush apart to clean it.

## Compressor After Use

When you are done painting and you have cleaned your airbrush thoroughly - empty the air tank of your compressor either by pressing the release valve under the airfilter/regulator or by unscrewing the tank draining plug. It's also good advice to use the drain valve every once in a while to remove any moisture that trapped in the tank due to humidity & moisture in the air.



## Brushes with Synthetic Bristles

We recommend that you get a couple of small paint brushes with synthetic bristles.

A synthetic brush will help you considerably when cleaning the airbrush of paint that is not removed when you just flush it with water or our Hobbynox SP Reducer/Cleaner.



## Dental Mini/Micro Brushes

If you really want to clean the hard to reach areas of your airbrush there are mini- and micro-sized brushes available from your local pharmacy. Their main intended use is to brush between your teeth but they're also excellent for cleaning your airbrush hard to reach spots!

There are several sizes available and you need to test which ones works the best for you - the ones we have tested is in the 0.5 to 0.7 mm range and they work very good.